

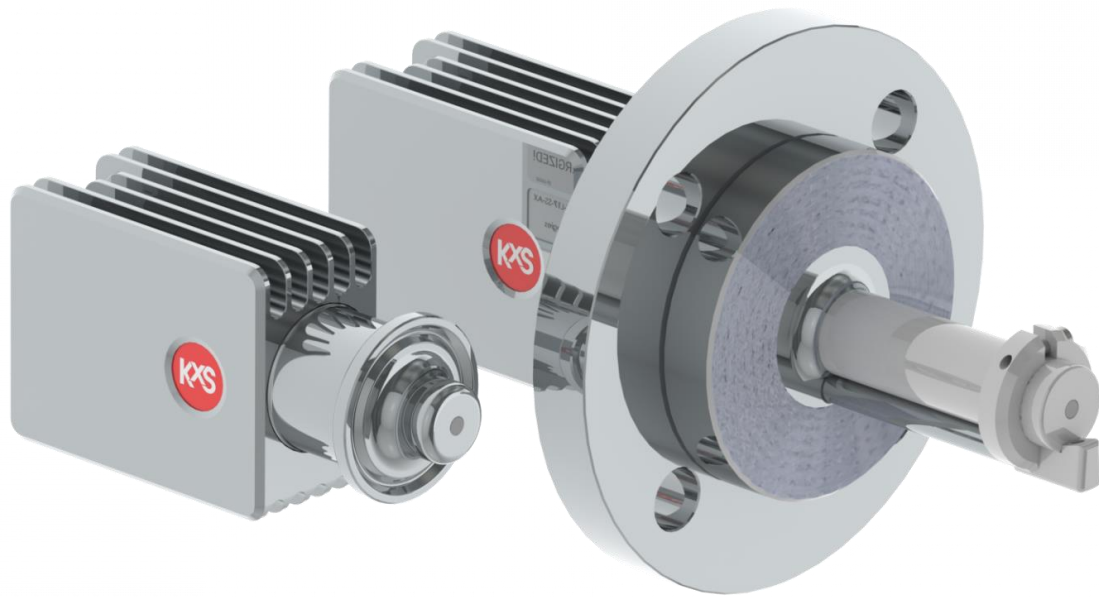

Excellence in heavy-duty
refractive index
measurement



**KxS industrial process refractometer
DCM-20 for chemical process control**

Technology that is built on over 40 years of industry-leading experience

KxS industrial process refractometer DCM-20 is engineered for precise, real-time concentration and density measurements in chemical processing, heavy industry, or any application requiring high precision under industrial or extreme conditions.

The DCM-20 consists of a compact, or probe sensor and it comes with flange or Sandvik coupling process connections and flow cells for easy installation in process pipes and vessels.

The DCM refractometer provides a full measurement range of 0-100%wt or g/l, utilizing two independent 4-20mA outputs and a digital Modbus TCP output for connectivity to automatic process control systems.

For enhanced functionality, an optional HMI unit offers a local display and interface, ensuring user-friendly operation.

Applications

- Define chemicals at loading and unloading stations
- Achieve and ensure product quality in Chlor-Alkali processes
- Correlate scrubber efficiency in liquid/gas treatment systems
- Optimize steam feed in glycerol evaporation processes
- Control chemical fiber and textile processes, particularly various spinning bath solutions and solvent recovery
- And more



Other typical applications

Caustic soda, Sulfuric acid, Sodium chloride, Sodium carbonate, Sodium sulfate, Urea, Caprolactam, Nylon salt, Amino acid, Ammonium fluoride, Ammonium hydroxide, Ammonium nitrate, Ammonium sulphate, Hydrogen peroxide, Coagulation bath, fertilizers and pesticides

Installation

KxS flow cell with flange connections
DCM-20-L (Compact model)

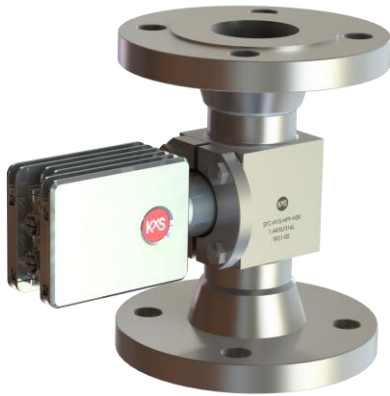

Tank or large pipe installation with flange connections
DCM-20-P (Probe model)

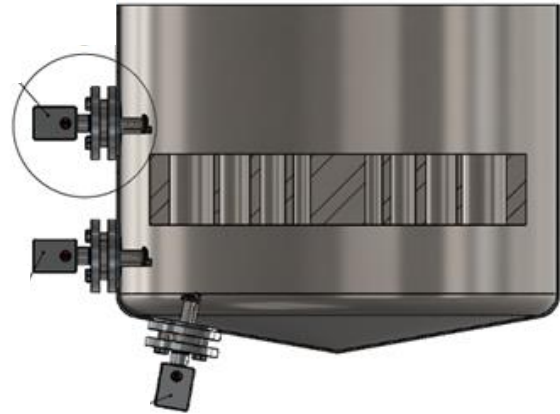

Digital and analog M12 connectors

The DCM-20 operates with a 24 VDC input power supply and offers flexible communication options, including analog (4-20 mA) and digital (Modbus TCP)

When using the analog signal, the digital port serves as a service port for configuration and diagnostics via a computer web browser, external display, or mobile device

All port options can be utilized simultaneously, providing seamless integration and monitoring capabilities

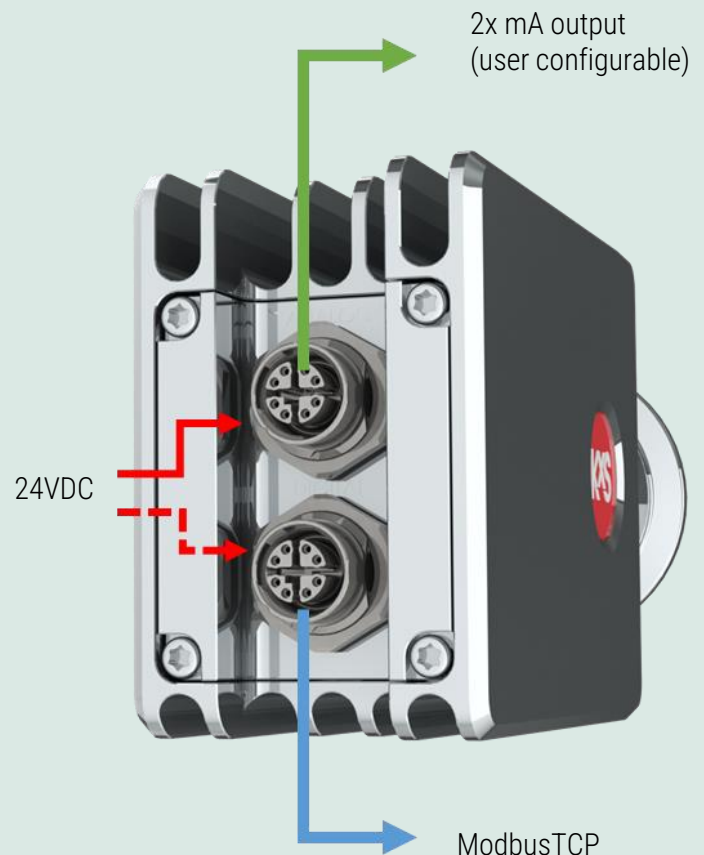

Key design features

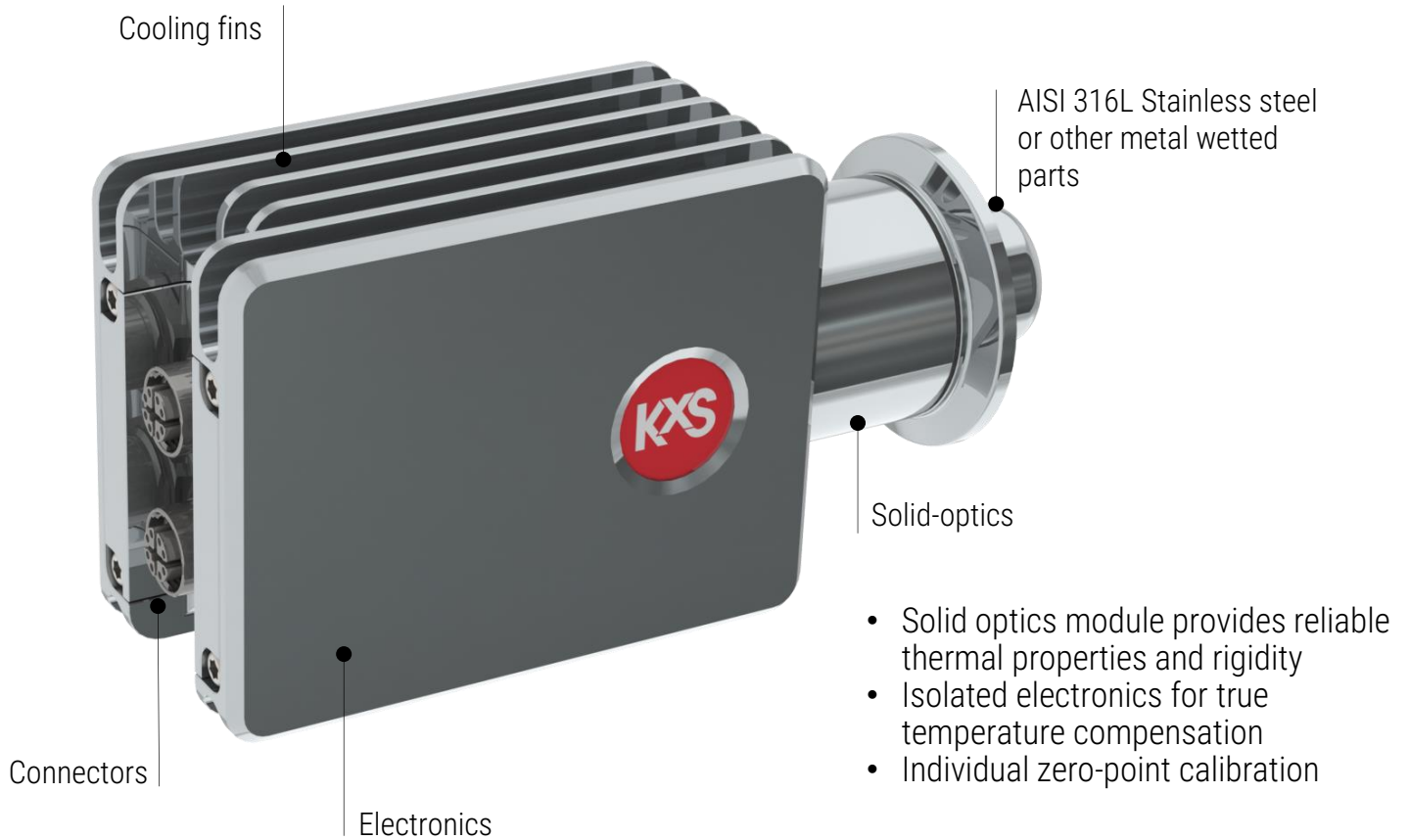
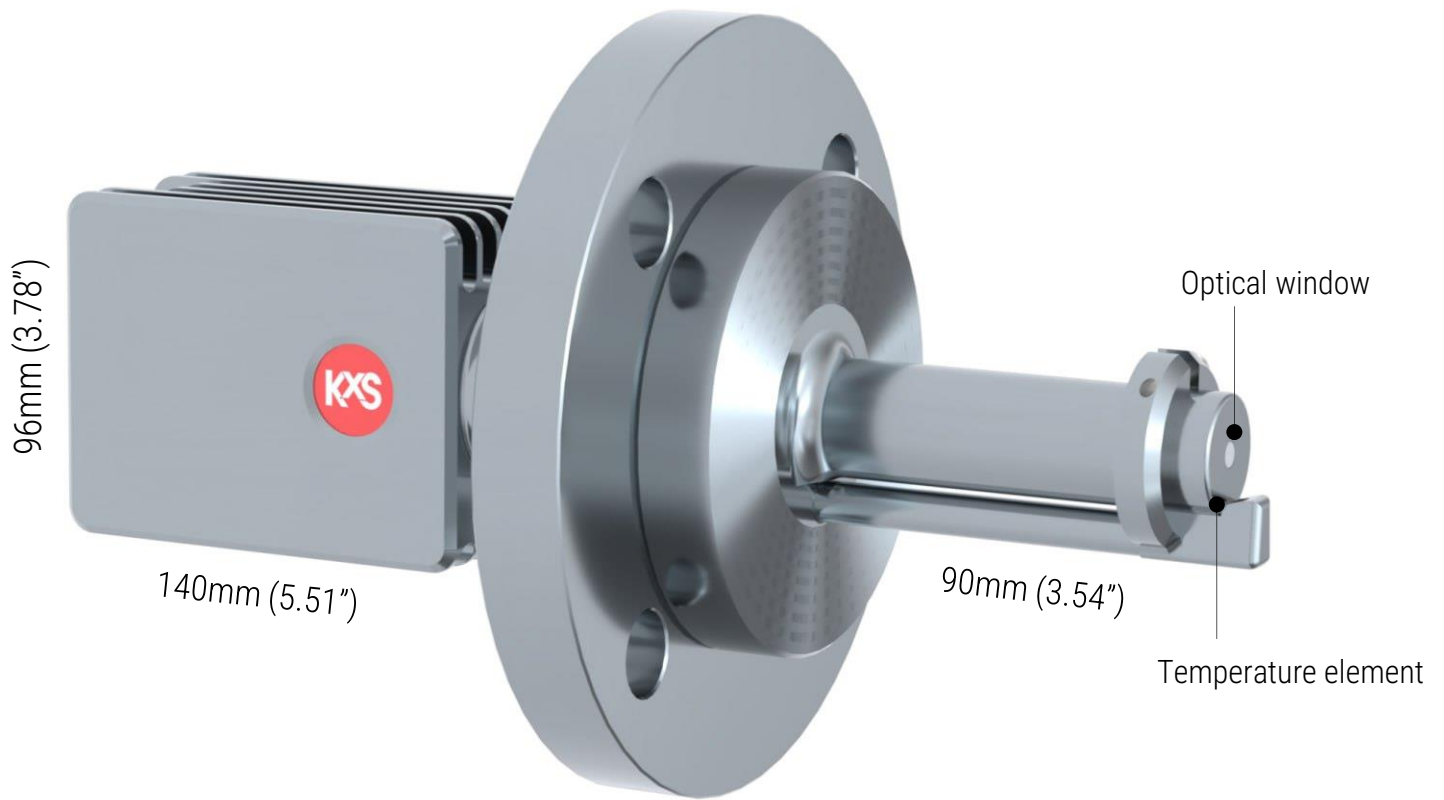

Optical refractive index measurement principle

KxS process refractometers DCM (digital concentration monitoring) employ the physical phenomenon of Refractive Index to define liquid concentration.

Optical concentration measurement is based on Snell's law and the critical angle of total reflection to provide precise readings.

Light is emitted from an LED and directed towards the interface between an optical window and the liquid being measured. As the concentration of the liquid changes, specific angles of the light are totally reflected and partially reflected back, producing light and shadow interface that is captured by a digital camera sensing element.

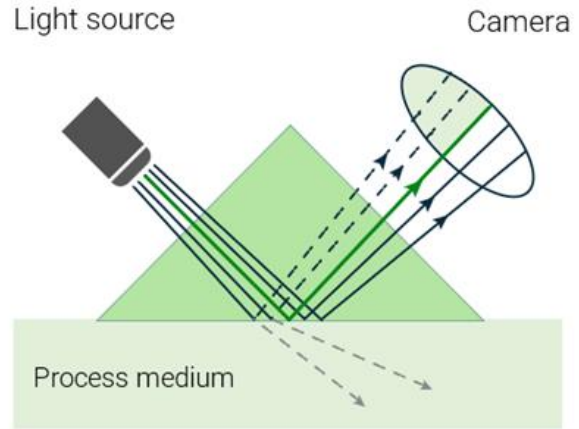

This interface is detected by the light-activated camera pixels and converted into refractive index (RI).

The RI values can be directly used or further translated into any concentration units, such as percentage by weight. This method ensures that measurement signals are provided instantaneously, allowing for real-time process control.

User interface

The DCM-20 measures refractive index and displays temperature-compensated concentration units in % by weight, density g/l or any engineering unit.

External displays with different sizes are available for connection through the sensor digital port. Computer, tablet or mobile phone with a web browser serves as user interface for accessing sensor diagnostics and settings.

Advanced optical image detection with proprietary pattern recognition.

Modular Connection Unit with wash relays



Web HMI

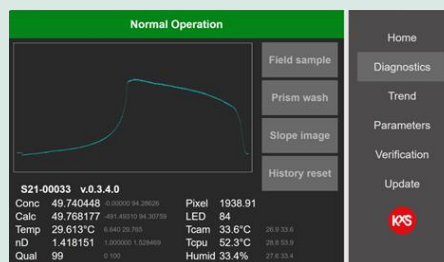
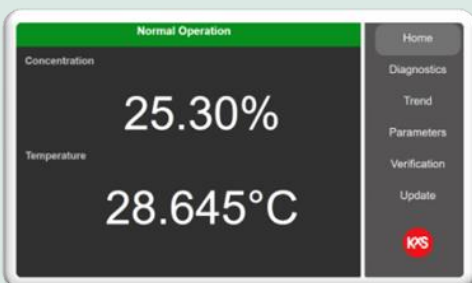

KxS Industrial process refractometer DCM-20 specifications

Refractive Index range:	Full range, nD=1.3200...1.5300 (equal by definition to 0...100%wt) Optional range nD=1.3600....1.5900 (high refractive index applications with YAG optical window)
Output units:	Conc% / g/cm ³ / refractive index unit RIU
Measurement precision:	± 0.025%wt
Measurement accuracy:	± 0.0006 refractive index unit RIU
Speed of response:	1 sec. undamped
Optics:	No mechanical adjustments and digital measurement with 4000 pixel camera, 589 nm wavelength (sodium D-line) light emitting diode (LED), built-in Pt-1000 temperature sensor (linearization according to IEC 751)
Temperature compensation:	Automatic, individual zero point calibration
Calibration:	NIST traceable calibration, verification with standard RIU liquids
Wetted parts:	AISI316L Stainless steel, Sapphire optical window, PTFE gasket Optional: Alloy 20, Hastelloy C-276, Titanium, Tantalum Sensor housing: AISI316 Stainless Steel
Wetted parts chemical compatibility	Depends on various operational conditions, such as pressure and temperature. The final responsibility for ensuring compatibility with the specific application rests with the customer. KxS provides assurance (e.g. material certifications) to verify compliance with the materials chosen by the customer.
Process connection:	Refractometer connections with DIN/ANSI/JIS flanges or flow cell flanges
Process pressure:	-1...55 bar, 14.5...800 psi (depending on process connection)
Process temperature:	-40°C (-40°F)...150°C (302°F) continuous process temperature
Ambient temperature:	-40°C (-40°F)...65°C (149°F)
Sensor protection class:	IP67, Nema 4X
Installation:	Indoor/Outdoor, unclassified area
Sensor weight:	5.7kg, 12.6lbs (DCM-20-P probe model) 1.3 kg, 2.9 lbs (DCM-20-L compact model)
Outputs and connections:	
Digital M12 connector:	24VDC power supply, Modbus TCP for user interface and PLC connection, normal cable length 10 m(33 ft), max 70 m(230 ft)
Analog M12 connector:	24VDC power supply, 2 pcs independent 4-20 mA user configurable outputs, normal cable length 10 m(33 ft), max, 200 m(660 ft). Max. load 1000 Ohm
Sensor Power consumption:	max. 2.5W
Options:	Modular Connection Unit enclosure with optional display/user interface Independent 7" or 15" Web HMI, full color touch screen interface, Optical window wash with steam or high pressure water. Direct integration with Rockwell's PLC for Ethernet IP communications ATEX/IECEx approval for Ex ec mc IIC t4 Gb/Gc